

Technical data sheet Starter battery

Battery type	12V 76Ah +R LB3	Product code	EM760B
---------------------	------------------------	---------------------	---------------

Specification	
Nominal voltage	12 V
Capacity (C20)	76 Ah at 25°C to 10,5V
Reserve capacity (25A discharge)	114 min
Cold cranking current (EN 18°C)	700 A
Cold cranking current (DIN 18°C)	420 A
Weight	16.6 kg ± 5%
Technology	Flooded/SLI

Overall dimensions	
Length	276 +0/-2 mm
Width	175 +0/-2 mm
Height	175 +0/-3 mm
Base hold-down	B13
Layout	0
Terminal type	1
Container material	PP
Box color	Black
Lid color	Black

Electrolyte	
Electrolyte type	H ₂ SO ₄
Electrolyte spec density at 25°C	1.28 ± 0.01 g/cm ³

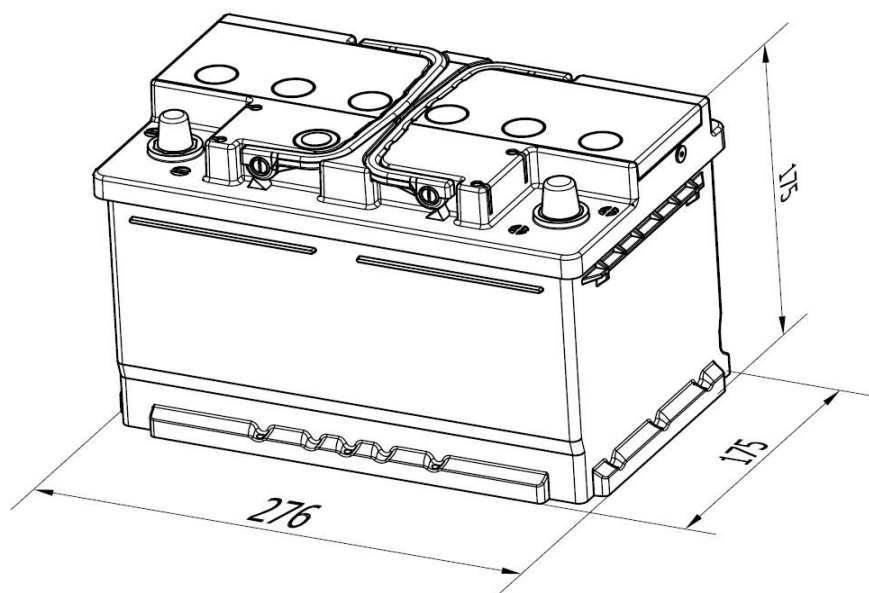

Cell properties	
Grid prod. technology	Punched
+ grid alloy	PbCa
Grid prod. technology	Continuous casting
- grid alloy	PbCa
Separator	
Type	PE
Thickness	1.0 - 1.2 mm

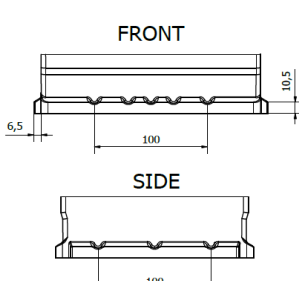
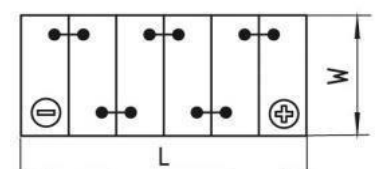
Drawings	
Base hold-down	Layout
	

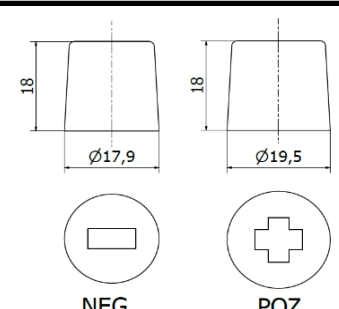
Terminal type	Key characteristics
	<p>Water consumption W3 Vibration level V2 Endurance level E1 Charge retention C2 Conform EN 50342/1</p>